



Commercial Flagpole - Glassfibre External - Ground Sleeve

5m - 8m

Commercial Flagpole - Glassfibre External - Ground Sleeve

Parts Checklist

- A 1 x Glassfibre Pole (5m - 8m) with Halyard (Double the length of the pole)
- B 1 x Ground Sleeve & Cap - (inside diameter - 125mm)
- C 1 x Fairlead & Saddle
- D 1 x Gold Onion Finial
- E 1 x Weight
- F 1 x Fixed Clip
- G 3 x Self Tapping Screws
- H 1 x Swivel Clip

A

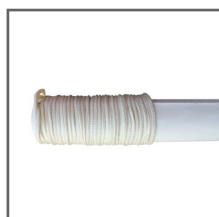

B



C



D



E



F

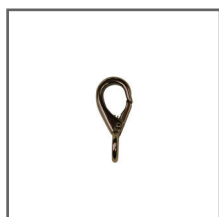

G



H



Commercial Flagpole - Glassfibre External - Ground Sleeve

Step 1

- » Dig foundation to required size see diagram (larger if ground is very sandy).
- » Order / mix concrete and place into hole (25 - 30 Newton - 50 slump - 20mm aggregate).
- » Ensure cap is fitted to ground sleeve to stop concrete from filling the sleeve.
- » Insert ground sleeve vertically into concrete, capped end first. Use spirit level to ensure ground sleeve is vertical. You may prefer to hold the ground sleeve in position with weighted cross batons.
- » Leave foundation to set for several days.

Ground Sleeve Installation - See Below (Flagpole Dimensions)

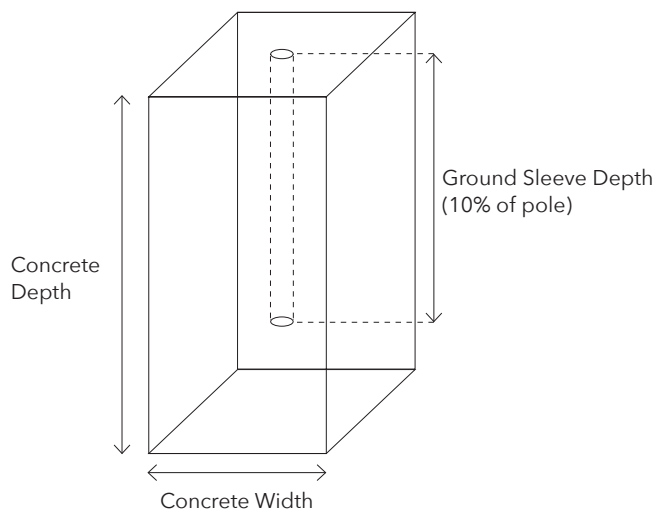

Flagpole Dimensions												
Flagpole Length (m)	5			6			7			8		
Butt Diameter Ø (mm)	120			120			120			120		
Top Diameter Ø (mm)	65			65			65			65		
Colour	Gel Coat White			Gel Coat White			Gel Coat White			Gel Coat White		
Material	Glassfibre			Glassfibre			Glassfibre			Glassfibre		
Strength	HD	EHD	UHD	HD	EHD	UHD	HD	EHD	UHD	HD	EHD	UHD
Wall Thickness (mm)	3	4	5	3	4	5	3	4	5	3	4	5
Finial	Gold Finial			Gold Finial			Gold Finial			Gold Finial		
Base Fixing	GS			GS			GS			GS		
Foundation Recommended (w2 x d)(mm)	500 x 1000			500 x 1000			500 x 1000			500 x 1000		
Recommended Flag Size (mm)	1830 x 910			1830 x 910			1830 x 910			2290 x 1140		
Maximum Wind Speeds (mph flagged)	30			30			30			30		

HD - Heavy Duty • EHD - Extra Heavy Duty • UHD - Ultra Heavy Duty • HBP - Hinged Base Plate • GS - Ground Sleeve

NB: We recommend that the concrete used in the bases should be of a C30 quality as normally purchased from a ready mixed concrete supplier. If purchaser is to mix concrete up themselves then the ratio of the mix i.e. Cement/Sand/Fine Aggregate must 1:2:3 which results in a very strong mix. Any deviation from the above advise may result in warranty claims being invalid. If in any doubt please contact supplier for clarification.

Commercial Flagpole - Glassfibre External - Ground Sleeve

Step 2

Unravel the halyard from the end of the flagpole. Thread the halyard through the base of the fairlead and saddle. Push the halyard through the hole running horizontally through the fairlead with a suitable object.

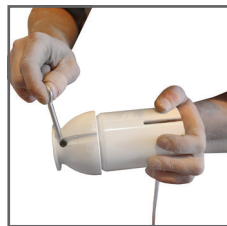
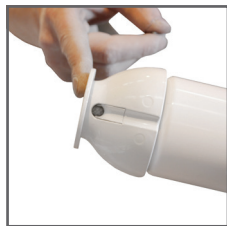

Step 3

Slide the saddle over the end of the pole and secure in place with self tapping screws.

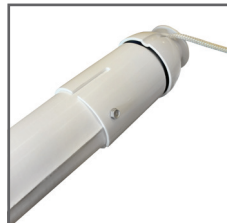
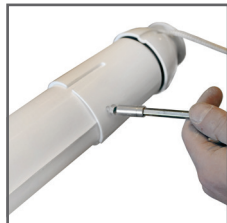

Step 4

Tie the fixed clip to the end of the halyard and make sure that it is secure.

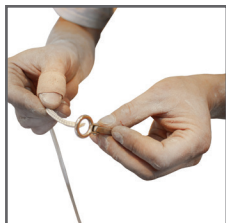

Step 5

Holding the halyard tight to the pole. Place the weight over the top of the flagpole.



Step 6

Attach the fixed clip to the looped weight.



Step 7

Screw the gold finial onto the fairlead and saddle and hand tighten.

(It is recommended that the pole is raised at this point. Slide the pole into the ground sleeve ensuring that the concrete has completely set)

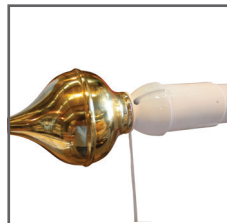

Step 8

Create a slip knot in the halyard. Double the halyard back on itself to create a horizontal loop, pull the halyard down behind the first loop and create a vertical loop. Bring the first loop around behind the vertical loop and pull back through to create a knot.



Commercial Flagpole - Glassfibre External - Ground Sleeve

Step 9

Place the toggle through the slip knot and pull tight.

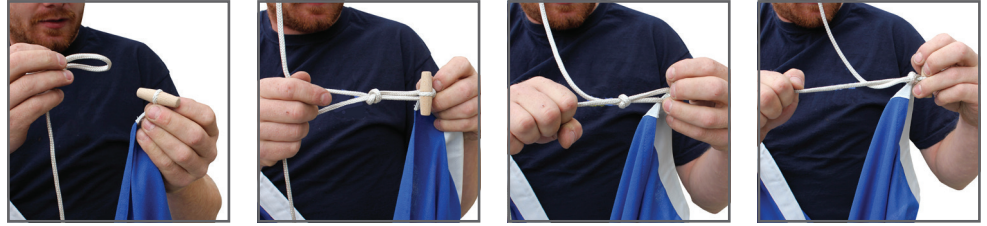

Step 10

Thread the halyard attached to the end of the flag through loop on the swivel clip. Secure the halyard to the clip by first creating a small loop, then wrapping the remaining halyard around itself 3 times. Thread the remaining halyard through the loop and pull tight to secure. When secure attach the swivel clip to the looped weight.



Step 11 - Metal Door

Hoist the flag to the top of the pole. When the arm has reached the top, pull the halyard to the right hand side and upwards. This will secure the halyard in the sprung loaded mechanism. Place the remaining halyard into the pole cavity and lock the door.



Step 11 - Plastic Door (6m)

Hoist the flag to the top of the pole. When the arm has reached the top, trap the halyard into the reverse jamming cleat. Insert the remaining loose halyard into the pole cavity and ensure the door is locked. Place the remaining halyard into the pole cavity and lock the door.

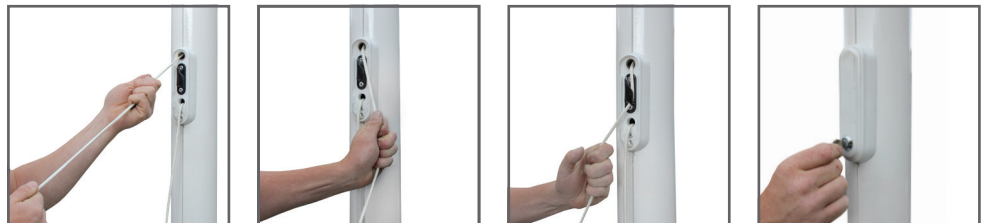

Commercial Flagpole - Glassfibre External - Ground Sleeve

Maintenance Recommendations For Glassfibre Flagpoles

Weekly

- Visual check of halyard for signs of wear or fraying, if necessary replace by sewing end of new halyard to end of old halyard and pull new halyard through top of flagpole.

Six Monthly

- Check stability of flagpole(s). Check operation of hinge bolt by removing nuts and washers and with the aid of an assistant walk flagpole down and place on a support (most important if ground collar 'in situ'). Do not remove levelling nuts.
- Check finial for stability, ease of rotation and check for damage to pulley groove. If necessary replace damaged or worn parts.
- For **external halyard** systems, check for signs of wear or fraying, replace if necessary. Check cleat for security and damage, replace if necessary.
- For **internal halyard** systems (including hoistable arms), check operation of Guardsman lock and jamming cleat, oil lock if necessary. Check for signs of wear or fraying of halyard, replace if necessary. Check for wear or damage on weight, ring and plastic clips. Check to see if any damage to flagpole at weight level. Repair or replace if necessary.
- For **swivel arm** systems, check for signs of wear of the rotating top, replace if necessary. Check for wear or damage on weight, ring and any clips. Check to see if any damage to flagpole at weight level. Repair or replace if necessary.
- Wash down flagpole with warm water and detergent to remove surface grime. Use a solvent cleaner for ingrained marks.
- Re-erect flagpole by walking the flagpole up, ensuring help is available. Check base nuts for tightness, adjust if necessary. Grease nuts to protect from rust. Check flagpole for vertical alignment.

Yearly

- Full service / inspection of the flagpole by a specialist should be carried out and log / report (provided by the contractor) kept of the date and works completed.

Adverse Weather Conditions

- Flags must be taken down in adverse weather conditions - i.e. if flying a standard flag and wind speeds are expected to exceed 30mph.
- If there is a requirement to keep flags flying in adverse weather conditions, then specialist storm flags (of one third the size) must be used, which will withstand wind speeds up to 45mph.
- The flagpole should be inspected as above prior to re-flying your flag.

Warranty

We provide a full product warranty which gives you peace of mind and appropriate protection of your glassfibre flagpole. See our warranty statement, which was supplied to you with our commercial paperwork, or, if not, is available on our website at www.flagpoles.co.uk. Failure to follow the maintenance recommendations set out here will, however, invalidate your warranty.

Harrison Flagpoles offer a range of maintenance and flagpole services. If you experience a flagpole problem you cannot solve or require your flagpoles to be serviced please call (01325) 355433.

Commercial Flagpole - Glassfibre External - Ground Sleeve

Glassfibre Flagpoles Ltd / Harrison Flagpoles

Warranty Statement

Harrison Flagpoles provides the following warranty to you, our direct customers, who have purchased glassfibre flagpoles that have been manufactured within our facilities:

We warrant that:

Our flagpoles will be free from defects in material or workmanship, provided that they have been **properly-installed** and **used normally** and **with responsible care**:

- for a five-year period from the date of despatch to you in respect of the glassfibre shaft.
- for a one-year period from the date of despatch to you in respect of all other parts (except the halyard, which is a consumable item).

Properly-installed in the context of this warranty statement means that you must follow all steps of our Installation Guide, which has been supplied with our commercial paperwork, or, if not, is available on our website at www.flagpoles.co.uk.

Used normally in the context of this warranty statement means that:

If the glassfibre flagpole is unflagged, then it will withstand wind gusts of up to 100 miles per hour.

When flying flags, the following rules must be followed:

- the flag must not exceed the maximum size recommended for a particular pole length, as specified in our Installation Guide.
- flags must be taken down in adverse weather conditions - ie. if flying a standard flag and wind speeds are expected to exceed 30mph.
- if there is a requirement to keep flags flying in adverse weather conditions, then specialist storm flags (of one third the size) must be used, which will withstand wind speeds up to 45mph.

With responsible care in the context of this warranty statement means that you must have followed the provisions of our statement "Maintenance Recommendations for Glassfibre Flagpoles", which has been supplied with our commercial paperwork, or, if not, is available on our website at www.flagpoles.co.uk.

We further warrant that:

Where our flagpoles are installed by us, or by our nominated installation contractors, then we warrant that the concrete base or fixings shall be free from defect for one year from the date of installation.

In the unlikely event of failure of our flagpoles, provided that you can demonstrate valid proof of purchase directly from us and provided that you have followed the installation, usage and care guidelines described in this warranty statement, then we will repair or replace the elements that have failed at our expense. The return by us of the repaired / replacement elements within a reasonable period of time shall constitute a complete and full discharge of any and all liability or damage related to such goods.

Exclusions

This warranty statement is limited to glassfibre flagpoles with a minimum butt diameter of 120mm. We issue no warranty for flagpoles with smaller butt diameters.

This warranty does not cover the expenses of removal, shipping costs to / from Glassfibre Flagpoles Ltd premises, the expense of reinstallation, or any other incidental or consequential costs.

This warranty is not intended to and shall not convey any third party beneficiary rights.

We make no other or further warranty, express or implied, including any warranty of merchantability or fitness for a particular purpose.

Harrison Flagpoles is a trading name of Glassfibre Flagpoles Ltd.