



Commercial Flagpole - Swivel Top - Hinge Base Plate

4m - 12m

Commercial Flagpole - Swivel Top - Hinge Base Plate

Foundation Dimensions

Profile View

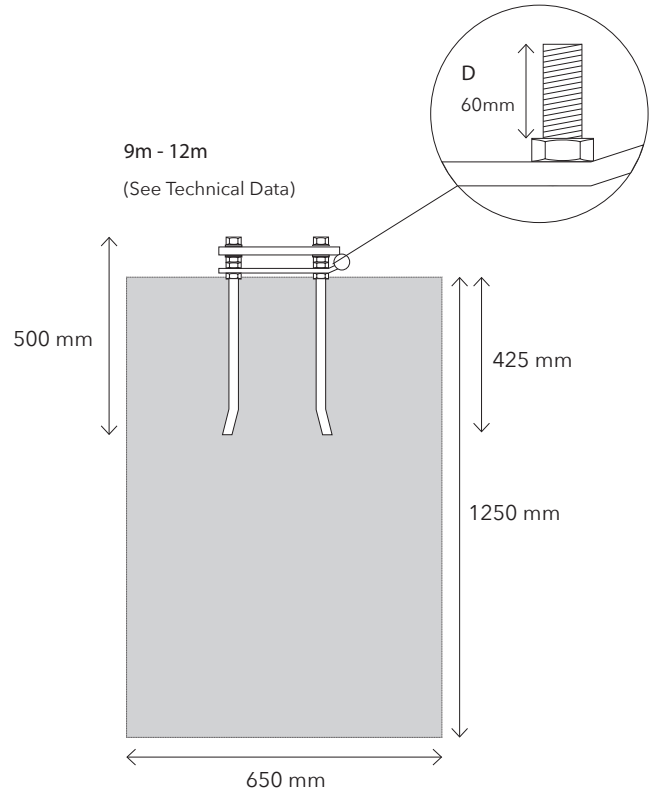
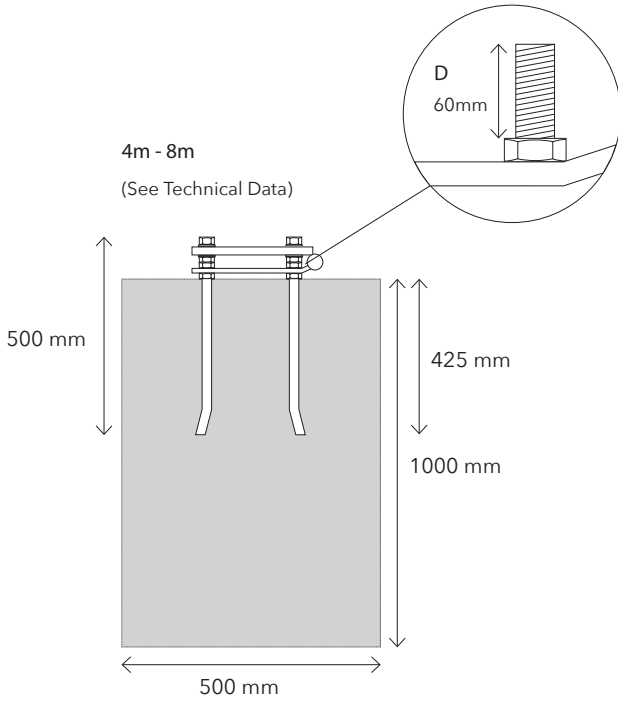

Flagpole Dimensions																					
Flagpole Length (m)	4			5			6			7			8			9			10		
Butt Diameter Ø (mm)	120			120			120			120			120			140			140		
Top Diameter Ø (mm)	65			65			65			65			65			65			65		
Colour	Gel Coat White			Gel Coat White			Gel Coat White			Gel Coat White			Gel Coat White			Gel Coat White			Gel Coat White		
Material	Glassfibre			Glassfibre			Glassfibre			Glassfibre			Glassfibre			Glassfibre			Glassfibre		
Strength	HD	EHD	UHD	HD	EHD	UHD	HD	EHD	UHD	HD	EHD	UHD	HD	EHD	UHD	HD	EHD	UHD	HD	EHD	UHD
Wall Thickness (mm)	3	4	5	3	4	5	3	4	5	3	4	5	3	4	5	4	5	6	4	5	6
Finial	Gold Finial			Gold Finial			Gold Finial			Gold Finial			Gold Finial			Gold Finial			Gold Finial		
Base Fixing	HBP			HBP			HBP			HBP			HBP			HBP			HBP		
Foundation Recommended (w2 x d)(mm)	500 x 1000			500 x 1000			500 x 1000			500 x 1000			500 x 1000			650 x 1250			650 x 1250		
Recommended Flag Size (mm)	1000 x 2000			1000 x 2000			1000 x 2000			1000 x 2500			1000 x 3000			1000 x 3500			1500 x 4000		
Maximum Wind Speed (mph flagged)	30			30			30			30			30			30			30		

Flagpole Dimensions						
Flagpole Length (m)	11			12		
Butt Diameter Ø (mm)	140			140		
Top Diameter Ø (mm)	65			65		
Colour	Gel Coat White			Gel Coat White		
Material	Glassfibre			Glassfibre		
Strength	HD	EHD	UHD	HD	EHD	UHD
Wall Thickness (mm)	5	6	7	5	6	7
Finial	Gold Finial			Gold Finial		
Base Fixing	HBP			HBP		
Foundation Recommended (w2 x d)(mm)	650 x 1250			650 x 1250		
Recommended Flag Size (mm)	1500 x 5000			1500 x 6000		
Maximum Wind Speed (mph flagged)	30			30		

HD - Heavy Duty • EHD - Extra Heavy Duty • UHD - Ultra Heavy Duty • HBP - Hinged Base Plate • GS - Ground Sleeve

NB: We recommend that the concrete used in the bases should be of a C30 quality as normally purchased from a ready mixed concrete supplier. If purchaser is to mix concrete up themselves then the ratio of the mix i.e. Cement/Sand/Fine Aggregate must 1:2:3 which results in a very strong mix. Any deviation from the above advice may result in warranty claims being invalid. If in any doubt please contact supplier for clarification.

Commercial Flagpole - Swivel Top - Hinge Base Plate

Parts Checklist

A	1 x Glassfibre Pole (4m - 12m)	H	8 x Washers
B	1 x Swivel Top	I	4 x Full Nuts (16mm)
C	1 x Gold Onion Finial	J	12 x Half Nuts (16mm)
D	1 x Banner Arm (23mm diameter x 1100mm)	K	3 x Self Tapping Screws
E	1 x Base Plate	L	1 x Eye Bolt, Nut & Carabiner* (50mm)
F	1 x Hinge Pin & Nut	M	1 x Weight
G	4 x Ground Rods (500mm)	N	1 x Carabiner (60mm)

A



B



C

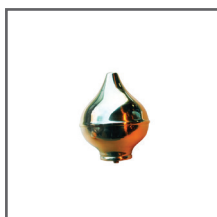

D



E



F



G

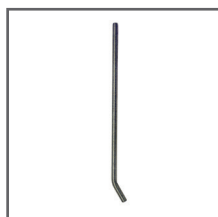

H



I



J



K



L

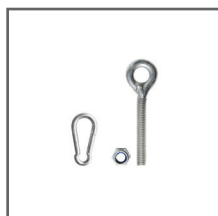

M



N

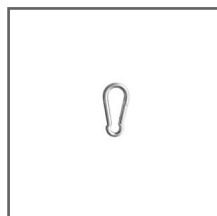

*Only required if flag finished with top eyelet

Please Note: 100mph Maximum Wind Speed (Unflagged). It is advised flags are taken down with winds exceeding 30mph.

Commercial Flagpole - Swivel Top - Hinge Base Plate

Step 1

- » Order/mix concrete and place into hole (25-30 newton - 50 Slump - 20mm aggregate)
- » Screw a half nut onto each threaded foundation bolt for distance 'D' as shown on the concrete foundation dimension.
- » Place the baseplate over the foundation bolts (the hinge on the ground plate should point upwards). Ensure that the ground plate is level and secure in position with half nuts.
- » Place the foundation bolts in the concrete at the correct depth and ensure the hinge on the ground plate points in the direction where the pole will be both raised and lowered. Ensure the foundation ground plate is level and leave a small space (15mm max) between the concrete foundation and the ground plate. This will allow adjustments to be made to ensure flagpole is completely vertical.
- » When the concrete has hardened mount one more half nut and washer on each foundation bolt.
- » Place hinging bolt partially through the ground plate ready to secure once the pole is in position. Offer the flagpole up to the foundation ground plate and slide hinge pin through both sections and secure with bolt. Once secure carefully lower the flagpole for the next step.



Step 2

Place the swivel top onto the end of the flagpole and line up with pre drilled holes. Secure the swivel top to the pole using the self tapping screws provided.

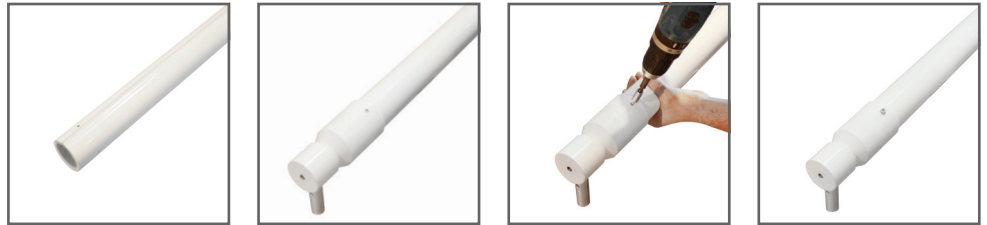

Step 3

Attach the 60mm carabiner clip to the eyelet at the bottom left hand corner of the flag then attach to the looped weight.

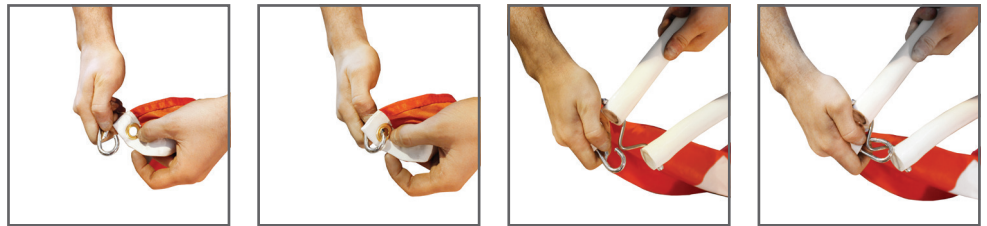

Step 4

Slide the looped weight over the flagpole followed by each mastband.



Step 5

Slide the sleeve of the flag over the banner arm and lining up the groove on the swivel top, attach the banner arm to the swivel top.

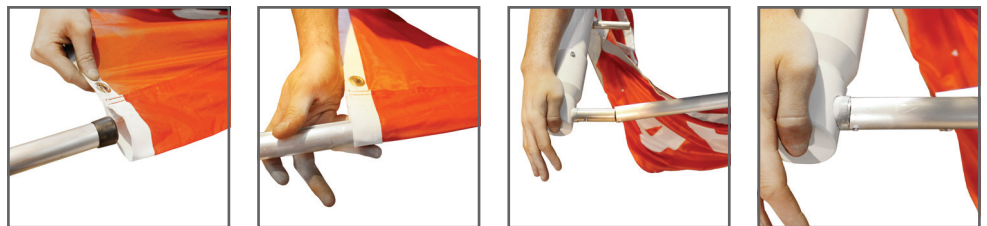

Commercial Flagpole - Swivel Top - Hinge Base Plate

Step 6 - Flag with top eyelet

Attach the 50mm carabiner to the eyebolt and place through the pre drilled holes in the banner arm and swivel top ensuring that the carabiner clip hangs downwards. Attach the lock nut to the eyebolt and tighten. Attach the carabiner clip to the eyelet just below the sleeve.

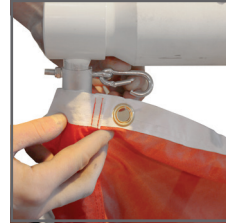

Step 7

Slide the sleeve of the flag over the banner arm and lining up the groove attach the banner arm to the swivel top.
(To erect the pole slide the fully assembled pole into the ground sleeve once concrete has completely set.)



Step 8

Place one large washer and nut over each foundation bolt in turn and secure. The half nuts immediately below the foot of the flagpole can be adjusted to ensure the flagpole is vertical. Once vertical lock the half nuts below and full nut above tight to the foot. Re-tension the bolts after 3-4 weeks.



Maintenance Recommendations For Glassfibre Flagpoles

Weekly

- Visual check of halyard for signs of wear or fraying, if necessary replace by sewing end of new halyard to end of old halyard and pull new halyard through top of flagpole.

Six Monthly

- Check stability of flagpole(s). Check operation of hinge bolt by removing nuts and washers and with the aid of an assistant walk flagpole down and place on a support (most important if ground collar 'in situ'). Do not remove levelling nuts.
- Check finial for stability, ease of rotation and check for damage to pulley groove. If necessary replace damaged or worn parts.
- For **external halyard** systems, check for signs of wear or fraying, replace if necessary. Check cleat for security and damage, replace if necessary.
- For **internal halyard** systems (including hoistable arms), check operation of Guardsman lock and jamming cleat, oil lock if necessary. Check for signs of wear or fraying of halyard, replace if necessary. Check for wear or damage on weight, ring and plastic clips. Check to see if any damage to flagpole at weight level. Repair or replace if necessary.
- For **swivel arm** systems, check for signs of wear of the rotating top, replace if necessary. Check for wear or damage on weight, ring and any clips. Check to see if any damage to flagpole at weight level. Repair or replace if necessary.
- Wash down flagpole with warm water and detergent to remove surface grime. Use a solvent cleaner for ingrained marks.
- Re-erect flagpole by walking the flagpole up, ensuring help is available. Check base nuts for tightness, adjust if necessary. Grease nuts to protect from rust. Check flagpole for vertical alignment.

Yearly

- Full service / inspection of the flagpole by a specialist should be carried out and log / report (provided by the contractor) kept of the date and works completed.

Adverse Weather Conditions

- Flags must be taken down in adverse weather conditions - i.e. if flying a standard flag and wind speeds are expected to exceed 30mph.
- If there is a requirement to keep flags flying in adverse weather conditions, then specialist storm flags (of one third the size) must be used, which will withstand wind speeds up to 45mph.
- The flagpole should be inspected as above prior to re-flying your flag.

Warranty

We provide a full product warranty which gives you peace of mind and appropriate protection of your glassfibre flagpole. See our warranty statement, which was supplied to you with our commercial paperwork, or, if not, is available on our website at www.flagpoles.co.uk. Failure to follow the maintenance recommendations set out here will, however, invalidate your warranty.

Harrison Flagpoles offer a range of maintenance and flagpole services. If you experience a flagpole problem you cannot solve or require your flagpoles to be serviced please call (01325) 355433.

Commercial Flagpole - Swivel Top - Hinge Base Plate

Glassfibre Flagpoles Ltd / Harrison Flagpoles

Warranty Statement

Harrison Flagpoles provides the following warranty to you, our direct customers, who have purchased glassfibre flagpoles that have been manufactured within our facilities:

We warrant that:

Our flagpoles will be free from defects in material or workmanship, provided that they have been **properly-installed** and **used normally** and **with responsible care**:

- for a five-year period from the date of despatch to you in respect of the glassfibre shaft.
- for a one-year period from the date of despatch to you in respect of all other parts (except the halyard, which is a consumable item).

Properly-installed in the context of this warranty statement means that you must follow all steps of our Installation Guide, which has been supplied with our commercial paperwork, or, if not, is available on our website at www.flagpoles.co.uk.

Used normally in the context of this warranty statement means that:

If the glassfibre flagpole is unflagged, then it will withstand wind gusts of up to 100 miles per hour.

When flying flags, the following rules must be followed:

- the flag must not exceed the maximum size recommended for a particular pole length, as specified in our Installation Guide.
- flags must be taken down in adverse weather conditions - ie. if flying a standard flag and wind speeds are expected to exceed 30mph.
- if there is a requirement to keep flags flying in adverse weather conditions, then specialist storm flags (of one third the size) must be used, which will withstand wind speeds up to 45mph.

With responsible care in the context of this warranty statement means that you must have followed the provisions of our statement "Maintenance Recommendations for Glassfibre Flagpoles", which has been supplied with our commercial paperwork, or, if not, is available on our website at www.flagpoles.co.uk.

We further warrant that:

Where our flagpoles are installed by us, or by our nominated installation contractors, then we warrant that the concrete base or fixings shall be free from defect for one year from the date of installation.

In the unlikely event of failure of our flagpoles, provided that you can demonstrate valid proof of purchase directly from us and provided that you have followed the installation, usage and care guidelines described in this warranty statement, then we will repair or replace the elements that have failed at our expense. The return by us of the repaired / replacement elements within a reasonable period of time shall constitute a complete and full discharge of any and all liability or damage related to such goods.

Exclusions

This warranty statement is limited to glassfibre flagpoles with a minimum butt diameter of 120mm. We issue no warranty for flagpoles with smaller butt diameters.

This warranty does not cover the expenses of removal, shipping costs to / from Glassfibre Flagpoles Ltd premises, the expense of reinstallation, or any other incidental or consequential costs.

This warranty is not intended to and shall not convey any third party beneficiary rights.

We make no other or further warranty, express or implied, including any warranty of merchantability or fitness for a particular purpose.

Harrison Flagpoles is a trading name of Glassfibre Flagpoles Ltd.